

零部件手册

苏州名创机电有限公司

SU ZHOU MINGCHUANG ELECTROMECHANICAL CO.,LTD





锥套

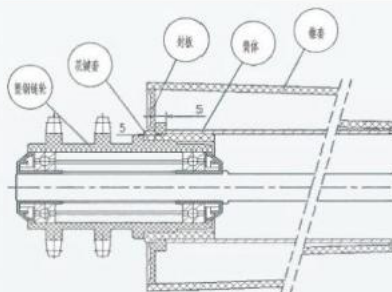
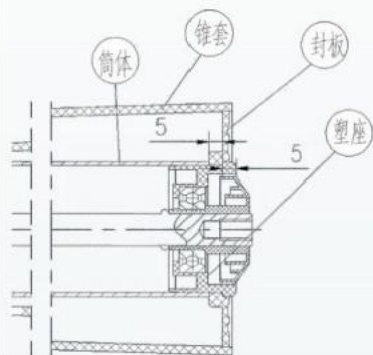

规格	有效长度 (mm)	小头 (mm)	大头 (mm)
半节套	50	53.1	55.9
1	100	56	62.8
2	100	62.9	69.1
3	100	69.2	74.4
4	100	74.5	80.8
5	100	81	87.1
6	100	87.3	93.7
7	100	93.9	100
8	100	100.2	106.3
9	100	106.5	112.6
10	100	112.8	118.3
11	100	118.5	124.7

直套



序号	规格	产品代码
1	50-70*100mm	16.1.18
2	50-70*120mm	16.1.19
3	50-80*80mm	16.1.20
4	60-80*100mm	16.1.21
5	60-80*120mm	16.1.22
6	76-96*160mm	16.1.23
7	50-60*100mm一体式	11.2.51
8	60-70*100mm一体式	11.2.52

链条机配件

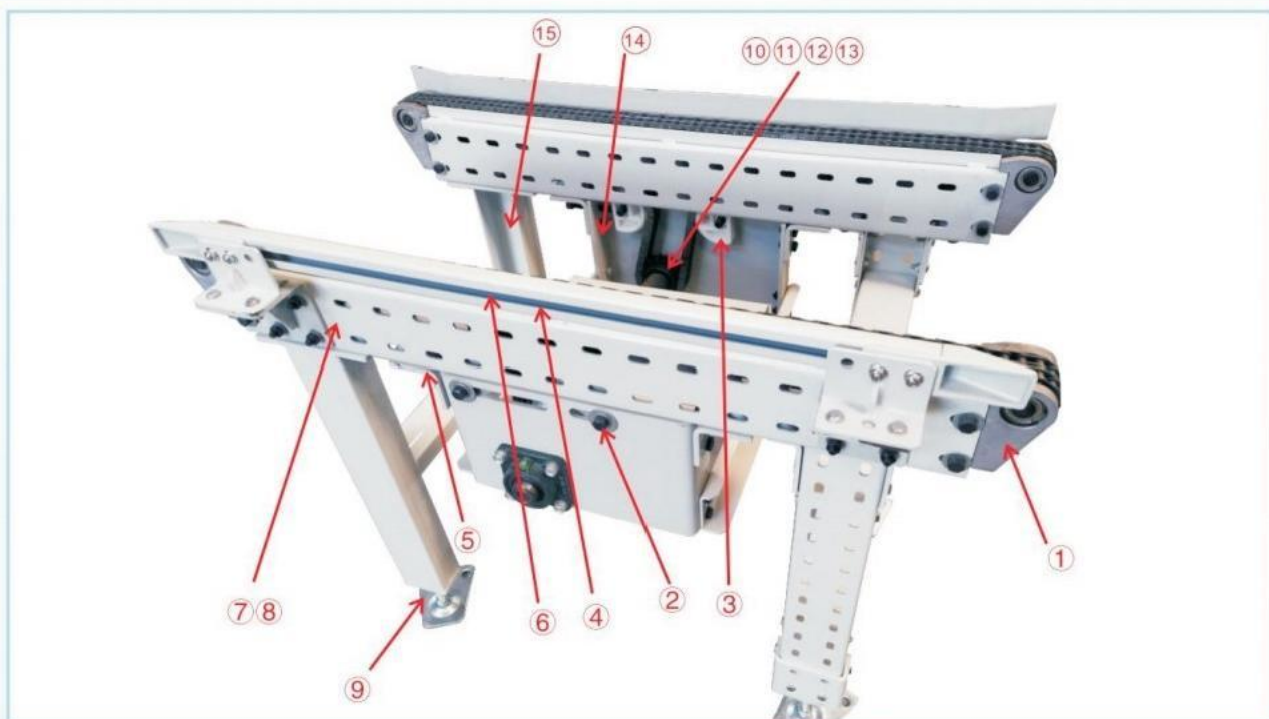

序号	品名	规格/型号	单位	数量	备注
1	头尾轮	铝合金配C10B-2链条	只	1	哈尔滨6004
2	涨紧轮	铝合金	只	1	哈尔滨6004
3	涨紧轮	高分子	只	1	可带方螺母M16
4	托条	18米/条, 超高分子材质	米	1	白色
5	滑块套件	56*40*12, 镀锌/发黑+塑料套件	套	1	
6	链条	C10B-2/3.048米/条	条	1	
7	机架、导槽	120*71*14*无孔+卡槽焊接	米	1	
8	机架、导槽	120*71*14*有孔+卡槽焊接	米	1	
9	杯脚	M20鸭掌*8mm*150mm	只	1	可定做规格
10	驱动电机链轮	10B15齿双排(可定制)	只	1	发黑
11	驱动电机链轮轴上用	10B17齿双排(可定制)	只	1	发黑
12	驱动轴	按照客户要求	支	1	调质发黑带轴套
13	带座轴承座	UCFC206(可定制)	只		
14	钣金件	按图制作	批		
15	支腿	按图制作	批		

滚筒线配件

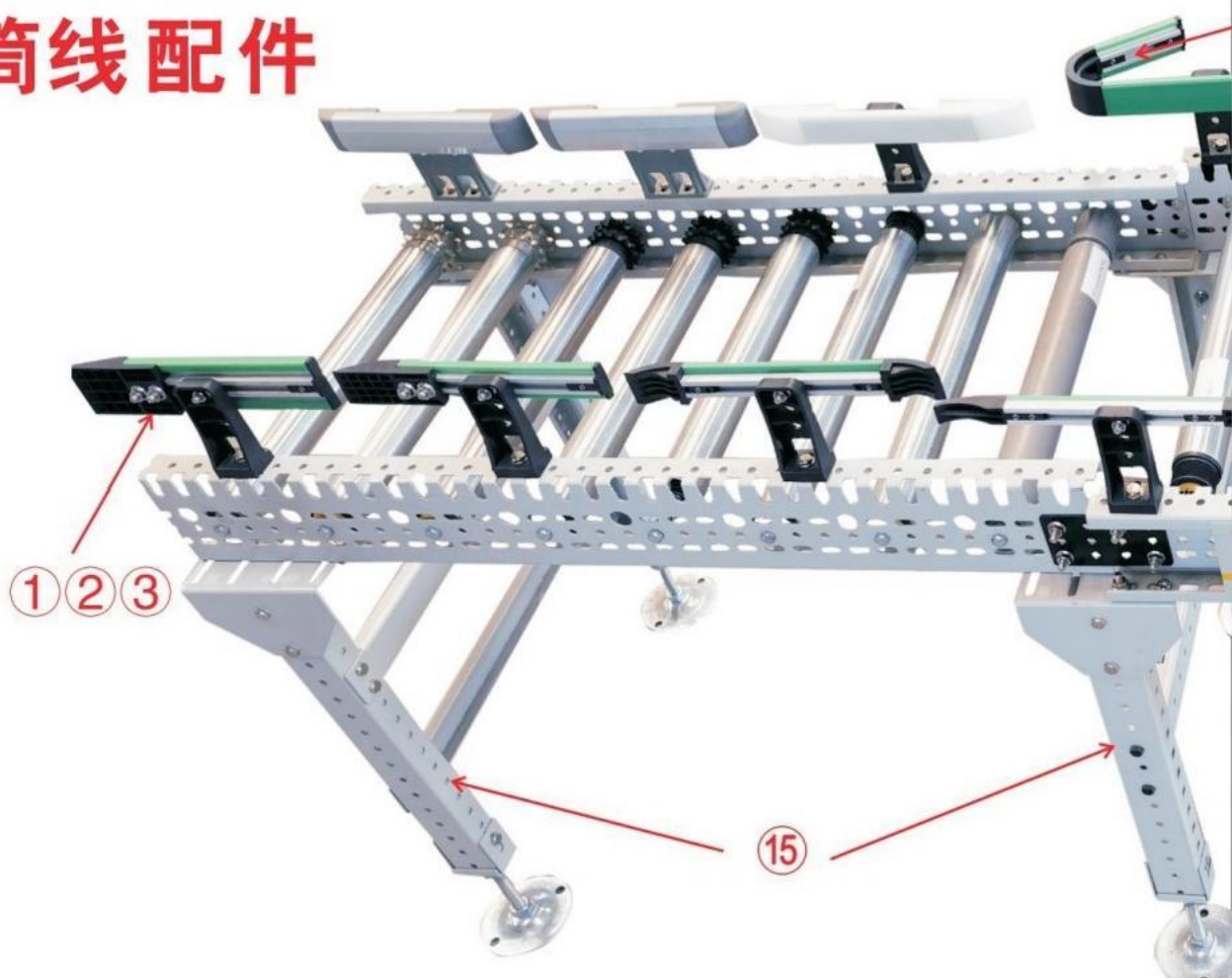

序号	品名	规格/型号	单位	备注
1	护栏	大C、中C、小C-38、小C-20、纯铝、纯塑	支	下料或3米 (可定制食品级)
2	支架	黑色护栏支架(100*40*30) 灰色护栏支架(100*80*30)	个	
3	标准导向头	大C、中C、小C-38、纯铝、纯塑、小C20	个	
4	机架防尘板	双色(灰、黄色)、灰色、深灰、红色、蓝色、黑色 (机架开口86MM)*3M	支	定制颜色
5	护栏弯头	30° 中C、90° 中C、可定制任意角度护栏	个	
6	连接件	护栏连接件、中C爬坡连接件、C型钢连接件	个	
7	封盖	C型钢端盖	个	
8	端盖	大C端盖、中C端盖、小C-20端盖	个	
9	C型钢	40*120*17*3、“35*115*14.5*3(机架开口86MM)	支	长度可定制

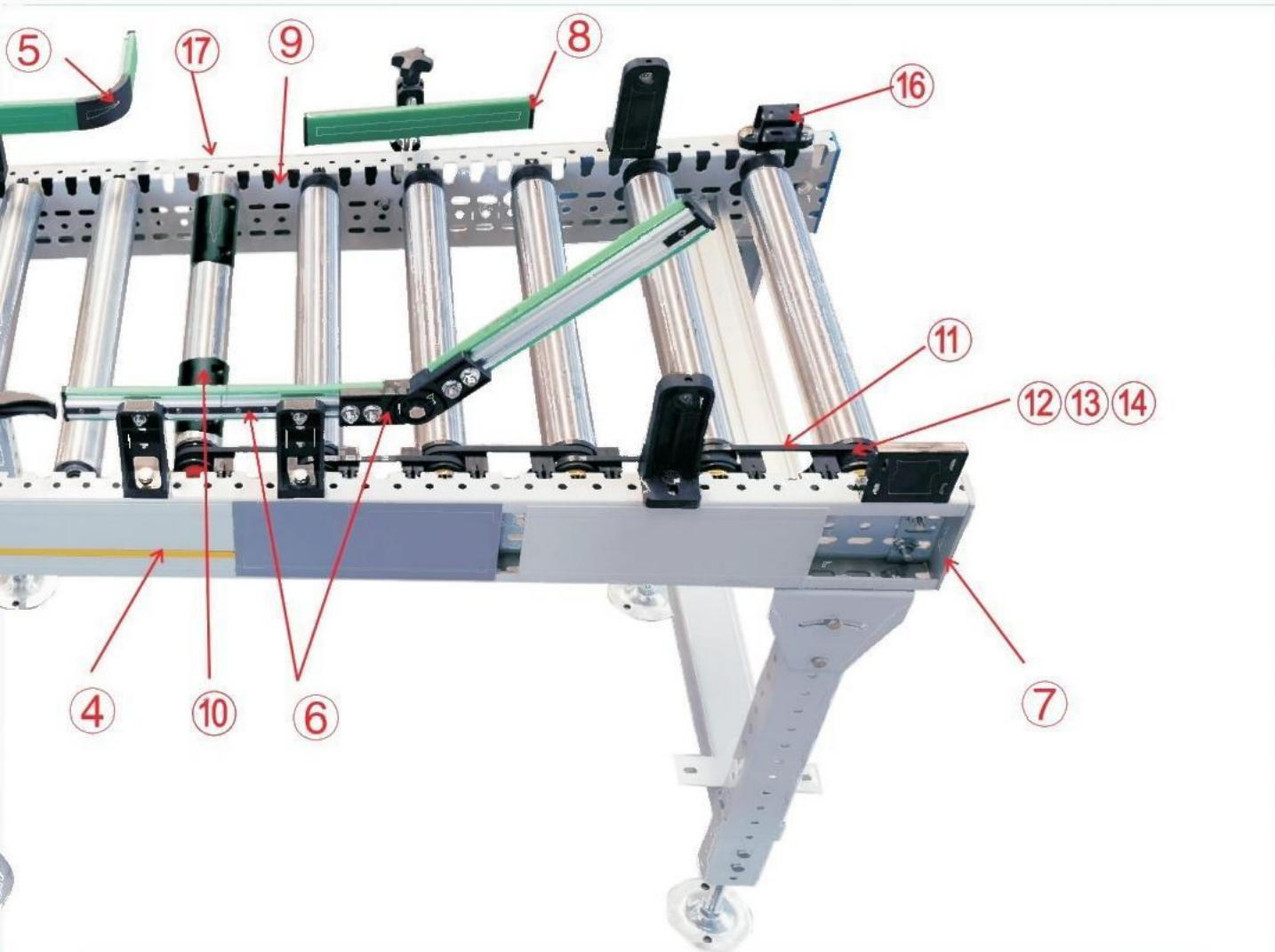

序号	品名	规格/型号	单位	备注
10	直套	50-70*100mm、50-70*120mm、50-80*80mm、 60-80*100mm、60-80*120mm、76-96*160mm、 50-60*100mm一体式、60-70*100mm一体式	个	
11	多楔带	2PJ、3PJ	个	
12	辊筒配件	多楔带轮、塑座	套	普通轴承
13	卡扣	S11六角轴辊筒卡扣、防夹手卡扣	个	
14	辊筒	按图定制	支	
15	支腿	按图定制	个	
16	光电支架	光电支架、光电支架垫片、光电支架反射板	个	
17	电滚筒配件	S11轴电滚筒支架	个	

① 护栏

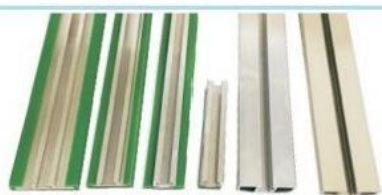

大C 护栏

铝50*12
塑60*12

10.1.26

中C 护栏

铝28.5*12.5
塑41*11

16.1.27

小C-38 护栏

铝19.5*15.7
塑38*7.5

16.1.28

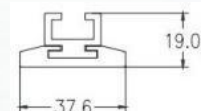
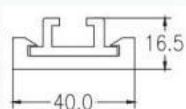
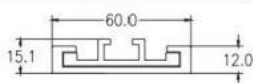

小C-20 护栏
铝19.5*14.7
塑20*6.5

16.1-29

纯铝护栏

11.2.65

纯塑护栏

11.2.68

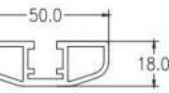
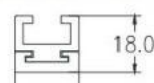

② 支架

黑色护栏支架

11.2.3

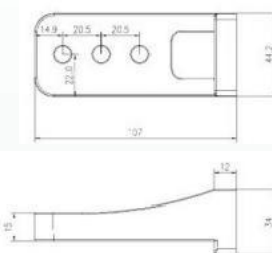

灰色护栏支架

11.2.30

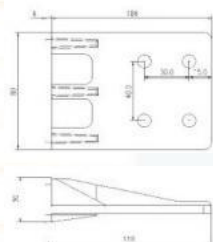

③ 导向头

大C

1.2.69

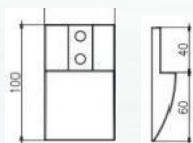

中C

11.2.70

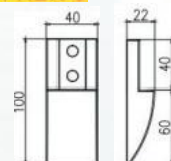

小C-38

11.2.21

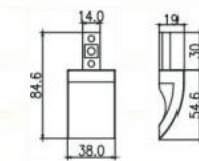

小C-20

11.2.95

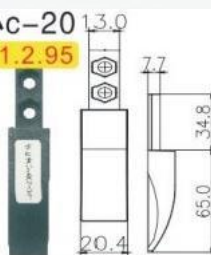

纯铝

66

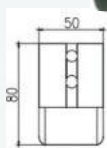

纯塑

11.2.66

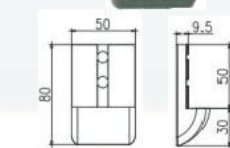

④ 机架防尘板

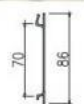

开70-C型钢
3mm厚机架防尘板
[0308154]

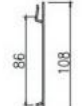

开86-C型钢
3mm厚机架防尘板
1.2.03



开120-C型钢
4mm厚机架防尘板

1.4.02

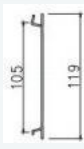

开105-C型钢
6mm厚机架防尘板

1.2.0104

⑤ 护栏弯头



90° 护栏弯头

11.2.23

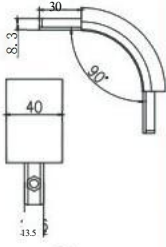

30° 护栏弯头

11.2.24

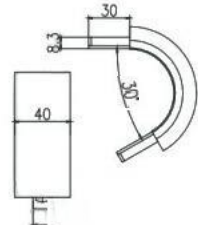

⑥ 连接件

中C爬坡连接件

11.2.22

护栏连接件

11.2.27

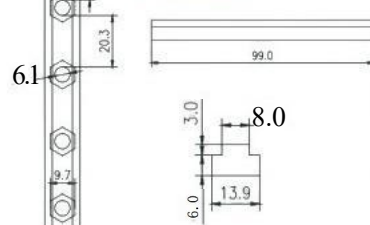

⑦ 封盖

C型钢封盖

11.2.96

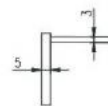
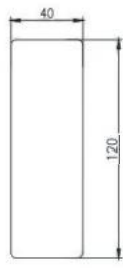
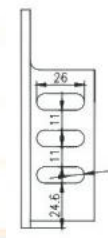

⑧端盖

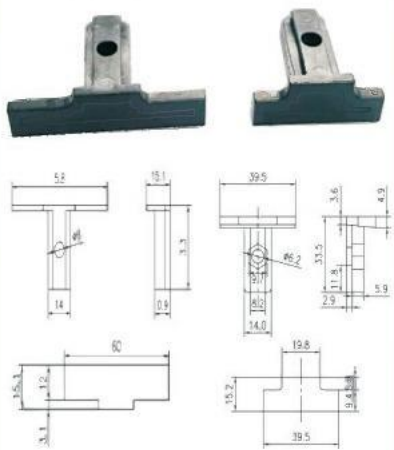

大C端盖

11.2.26

中C端盖

11.2.25

⑨C型钢

11.2.01

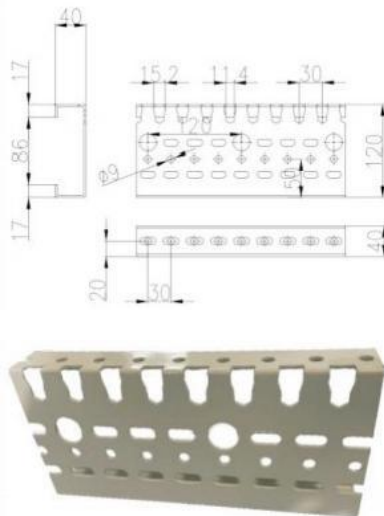

⑩直套

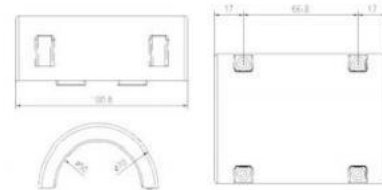

⑪多楔带



中心距	型号
60	PJ256
75	PJ286
90	PJ314
100	PJ336
120	PJ376
125	PJ390
150	PJ435

⑬卡扣

六角轴卡扣

11.2.10

防夹手卡扣

16.1.40



⑮支腿

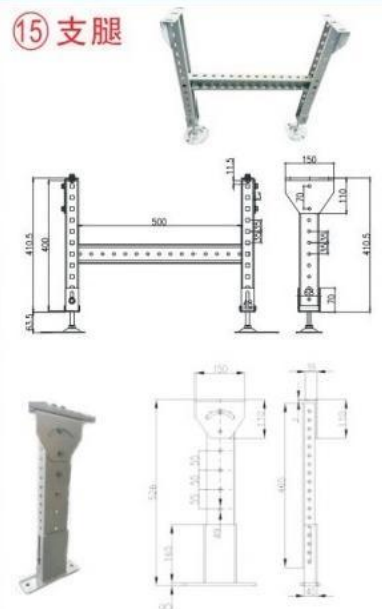

⑭ 辊筒

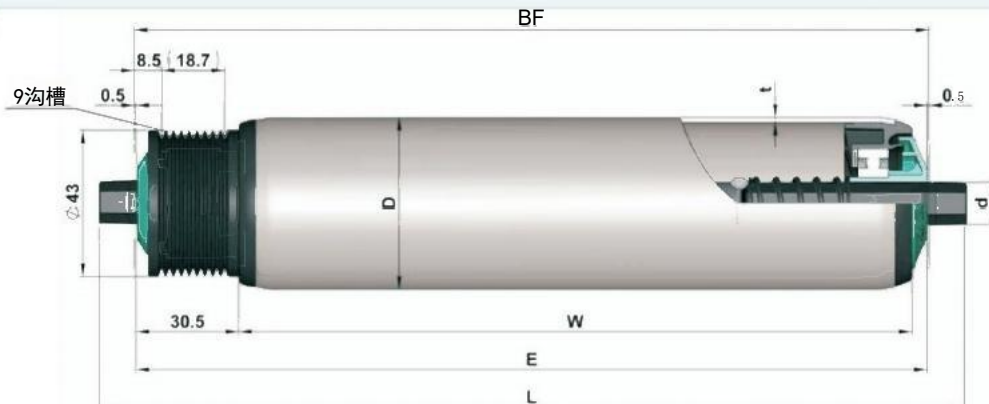

6光电支架

11.2.108

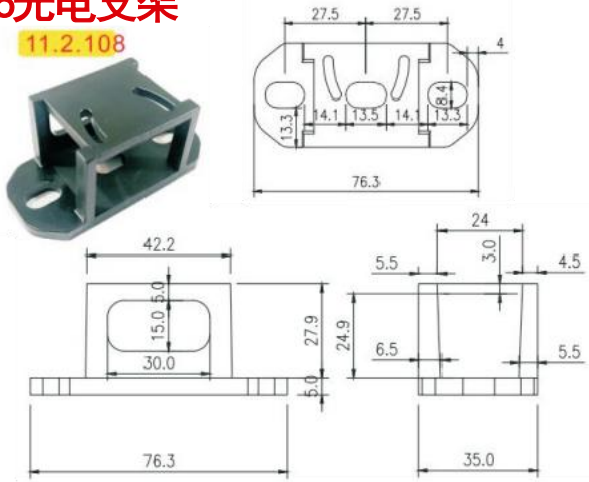

6 光电支架垫片

11.2.11 0

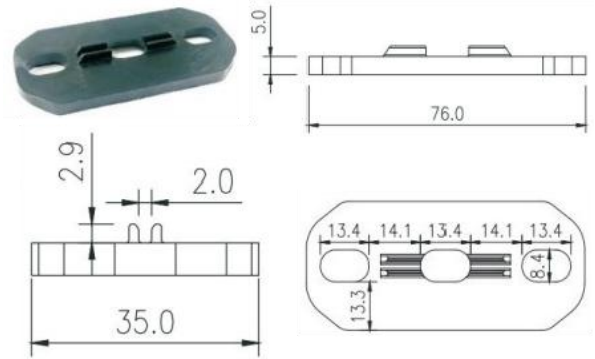

⑩光电支架反射板

1.2.11

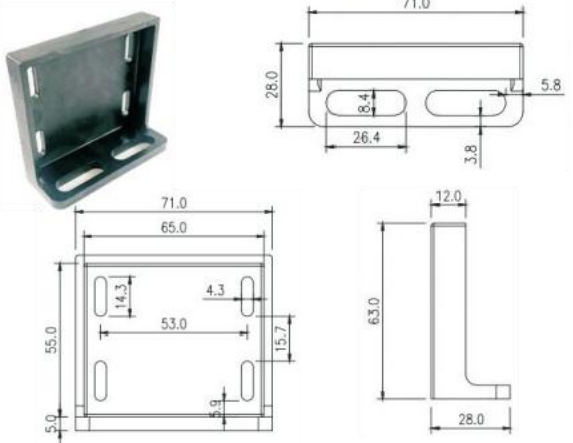

① 电滚筒固定支架

16.1.64

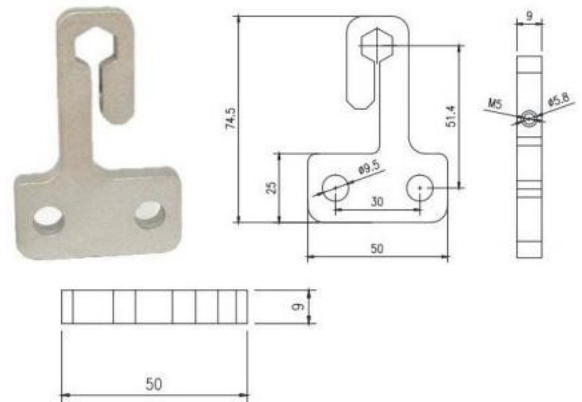

1



2



3

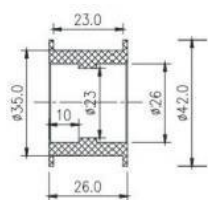
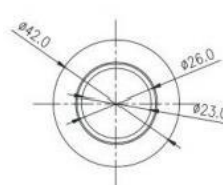
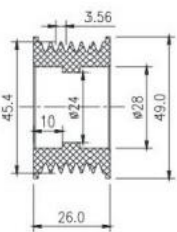
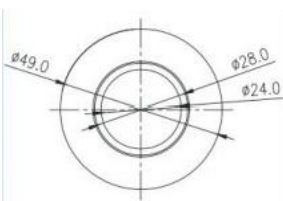

C

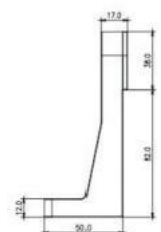
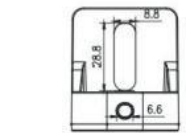

序号	品名	规格	用途
1	Pk多楔带轮	$\phi 49 \times L26$	皮带线
2	支撑惰轮	$\phi 42 \times L26$	
3	滚筒支架	15轴	15轴滚筒支架

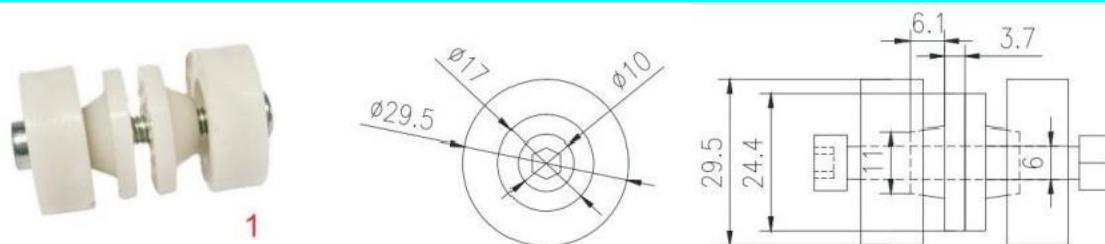

序号	品名	规格	用途
1	皮带导向轮	白色/绿色、 φ30*11*2*M5螺杆*L50	转弯皮带机

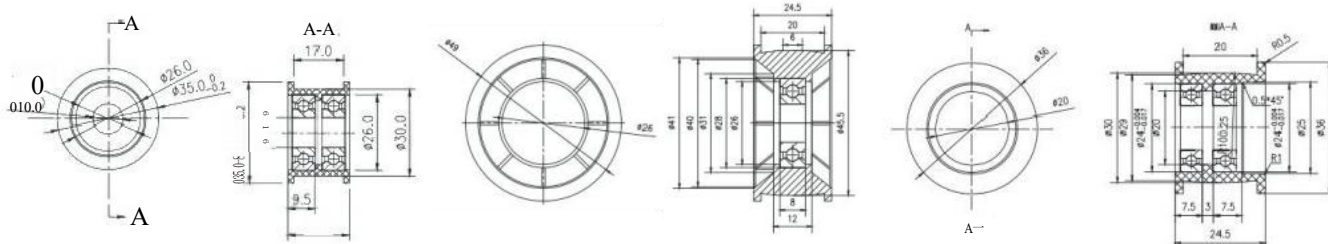

序号	品名	规格	用途
1	导向轮	φ30*L21	皮带机
2	张紧轮	D49.2*d45.5*L24.5配6001	
3	张紧轮	D36*d30*L24.5 配6901*2	



序号	品名	规格	轴径
1	同步带轮	T5-26齿	12轴、S11六角轴、15轴
2	花键套	501.2、501.5、502.0、601.5、 602.0、602.5、603.0	
3	0带轮501.2-12	501.2、501.5	12轴、S11六角轴、15轴

多楔带轮

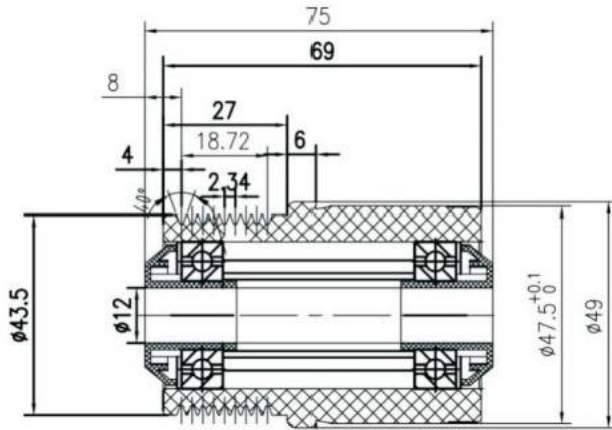

序号	规格	轴径
1	501.0	12轴、s11六角轴、15轴
2	501.2	12轴、s11六角轴、15轴
3	501.5	12轴、s11六角轴、15轴
4	601.5	12轴、s11六角轴、15轴
5	602.0	12轴、s11六角轴、15轴

塑钢链轮

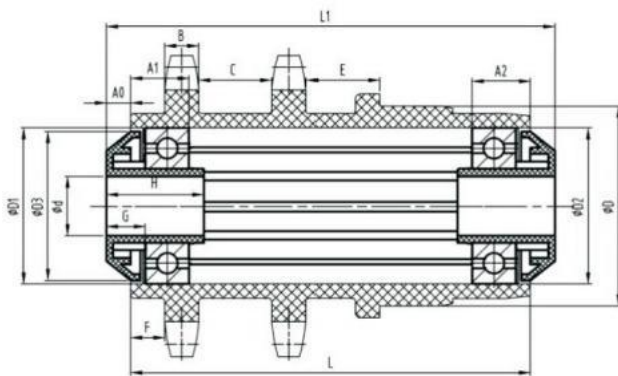

序号	规格	轴径
1	11T单链	12轴、S11六角轴
2	11T单链积放	12轴、S11六角轴
3	11T双链	12轴、S11六角轴
4	11T双链积放	12轴、S11六角轴
5	14T单链	12轴、s11六角轴、15轴
6	14T单链积放	12轴、s11六角轴、15轴
7	14T双链	12轴、s11六角轴、15轴
8	14T链积放	12轴、s11六角轴、15轴

不收口塑座

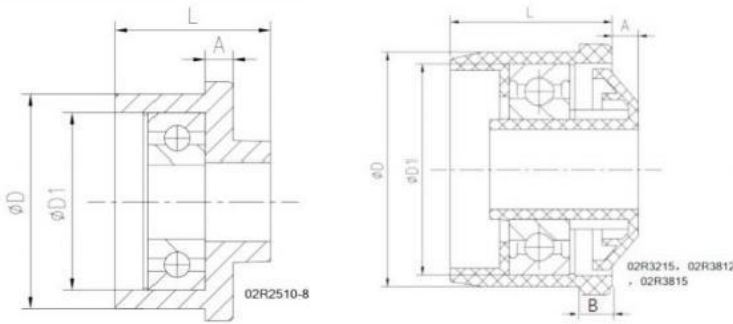

序号	规格	ΦD	A	B	轴径
1	251.0 -8	Φ23.2	4mm		8轴
2	251.0 0-8凸台	Φ23.2	4mm	4mm	8轴
3	321.0	Φ30.2	5mm	4mm	8轴、10轴、12轴
4	321.2	Φ29.8	5mm	4mm	8轴、10轴、12轴
5	321.5	Φ29.2	5mm	4mm	8轴、10轴、12轴
6	381.0	Φ36.2	5mm	5mm	8轴、10轴、12轴、s11六角轴、15轴
7	381.2	Φ35.8	5mm	5mm	8轴、10轴、12轴、s11六角轴、15轴
8	381.5	Φ35.2	5mm	5mm	8轴、10轴、12轴、s11六角轴、15轴
9	382.0	Φ34.2	5mm	5mm	8轴、10轴、12轴、s11六角轴、15轴
10	383.0	Φ32.2	5mm	5mm	8轴、10轴、12轴、s11六角轴、15轴
11	421.5	Φ39.3	5mm	5mm	8轴、10轴、12轴、s11六角轴、15轴
12	501.0	Φ48.3	5mm	5mm	8轴、10轴、12轴、s11六角轴、15轴
13	501.2	Φ47.9	5mm	5mm	8轴、10轴、12轴、s11六角轴、15轴
14	501.5	Φ47.3	5mm	5mm	8轴、10轴、12轴、s11六角轴、15轴
15	502.0	Φ46.3	5mm	5mm	8轴、10轴、12轴、s11六角轴、15轴
16	502.5	Φ45.3	5mm	5mm	8轴、10轴、12轴、s11六角轴、15轴
17	503.0	Φ44.3	5mm	5mm	8轴、10轴、12轴、s11六角轴、15轴
18	571.5	Φ54.3	5mm	5mm	8轴、10轴、12轴、s11六角轴、15轴
19	572.0	Φ53.3	5mm	5mm	8轴、10轴、12轴、s11六角轴、15轴
20	601.2	Φ57.9	5mm	5mm	8轴、10轴、12轴、s11六角轴、15轴
21	601.5	Φ57.3	5mm	5mm	8轴、10轴、12轴、s11六角轴、15轴
22	602.0	Φ56.3	5mm	5mm	8轴、10轴、12轴、s11六角轴、15轴
23	602.5	Φ55.3	5mm	5mm	8轴、10轴、12轴、s11六角轴、15轴
24	603.0	Φ54.3	5mm	5mm	8轴、10轴、12轴、s11六角轴、15轴
25	761.5	Φ73.3	5mm	5mm	15轴、20轴
26	762.0	Φ72.3	5mm	5mm	15轴、20轴
27	763.0	Φ70.3	5mm	5mm	15轴、20轴

收口塑座

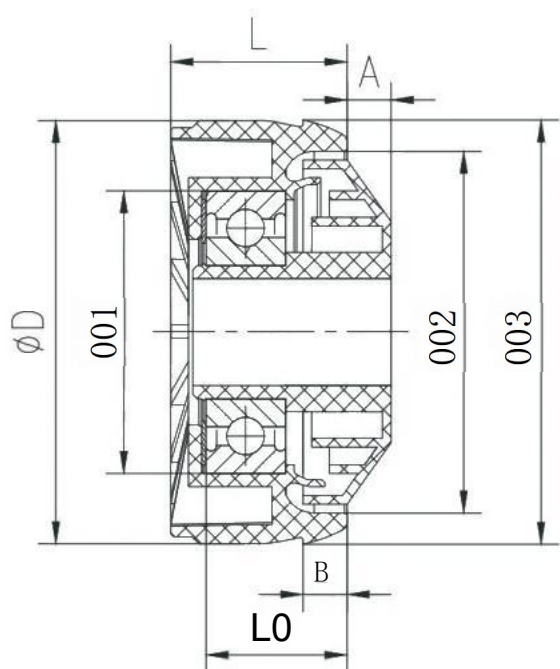

序号	规格	ϕD	A	B	轴径
1	381.2	$\phi 35.9$	5mm	5mm	12轴、s11六角轴、15轴
2	381.5	$\phi 35.3$	5mm	5mm	12轴、s11六角轴、15轴
3	501.2	$\phi 47.9$	5mm	5mm	12轴、s11六角轴、15轴
4	501.5	$\phi 47.3$	5mm	5mm	12轴、s11六角轴、15轴
5	502.0	$\phi 46.3$	5mm	5mm	12轴、s11六角轴、15轴
6	601.2	$\phi 57.9$	5mm	5mm	12轴、s11六角轴、15轴
7	601.5	$\phi 57.3$	5mm	5mm	12轴、s11六角轴、15轴
8	602.0	$\phi 56.3$	5mm	5mm	12轴、s11六角轴、15轴
9	761.5	$\phi 73.3$	5mm	5mm	15轴、20轴
10	762.0	$\phi 72.3$	5mm	5mm	15轴、20轴

福来轮



GA-01 系列

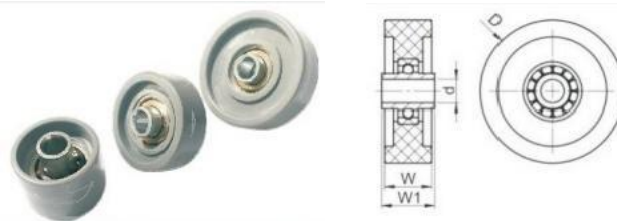

型号	材质	d	D	W	W1	静载(kg)	动载(kg)	自重(g)
GA-01-8	ABS	φ8.1	φ48.5	16	18	40	60	35
GA-01A-8	ABS	φ8.1	φ38	14.3	18	35	50	26
GA-01B-8	ABS	φ8.1	φ30	24.1	28.5	20	25	25.5

GA-02 系列

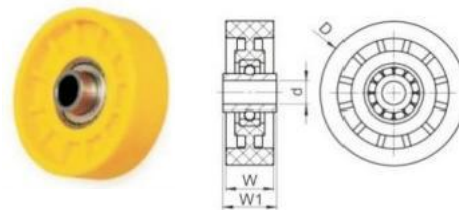

型号	材质	d	D	W	W1	静载(kg)	动载(kg)	自重(g)
GA-02-8	ABS	φ8.1	φ48.5	16	18	40	60	30

GB 系列

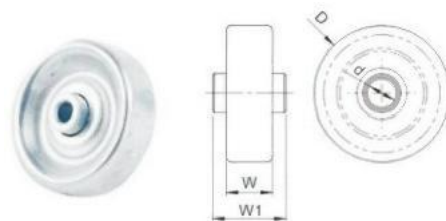

型号	材质	d	D	W	W1	静载(kg)	动载(kg)	自重(g)
GB-01-6	钢制/镀锌	φ6.1	φ38	13.1	20.4	8	10	56
GB-02A-8	钢制/镀锌	φ8.1	φ48	15.3	18	8	15	66
GB-02B-6	钢制/镀锌	φ6.1	φ48	15.3	19.9	35	45	105

防尘盖

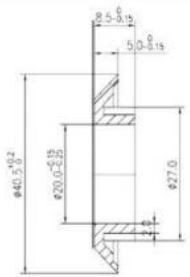
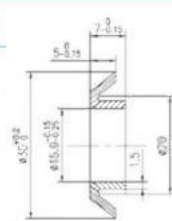
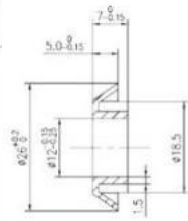

序号	规格	尺寸	用途
1	12轴防尘盖	φ 12*φ 25.7	搭配6001轴承使用
2	15轴防尘盖	φ 15*φ 30	搭配6002轴承使用
3	20轴防尘盖	φ 20*φ 40	搭配6004轴承使用
4	12轴大防尘盖	φ 12*φ 30	搭配6201轴承使用
5	15轴大防尘盖	φ 15*φ 33	搭配6202轴承使用
6	20轴大防尘盖	φ 20*φ 45	搭配6204轴承使用

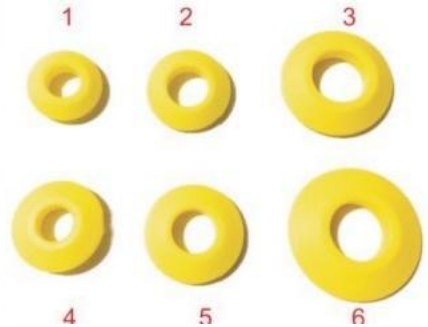

螺钉塞

序号	规格	用途
1	M6螺钉塞	防止滚筒使用前轴链轮、轴承、轴套、通轴等掉出，使用滚筒时拔出即可。
2	M8螺钉塞	
3	M10螺钉塞	
4	M12螺钉塞	



轴套隔套

序号	规格	用途
1	12轴轴套L15.5*φ 15.8	保护内圈，防止轴承内环的磨损，并同时起到定位和支撑作用
2	15轴轴套L15.3*φ 20.5	
3	12轴隔套L25*φ 26	分隔两个轴承，防止彼此接触和摩擦，从而避免损坏和磨损，同时保证轴的正常运转。
4	15轴隔套L15.1*φ 26	



弹性轴

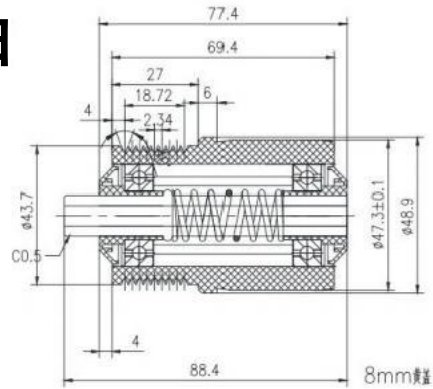

序号	品名	规格
1	5015-S11弹簧压入式多楔带轮	S11

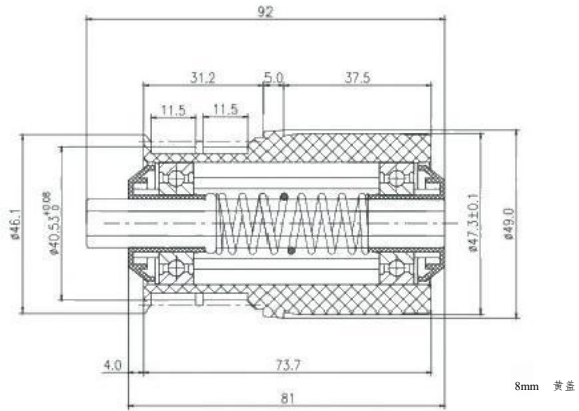

序号	品名	规格
1	5015-S11弹簧压入式同步带轮	S11

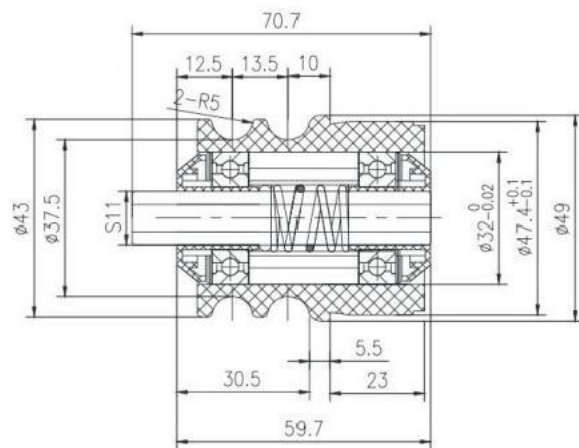

序号	品名	规格
	5015-S11弹簧压入式0带轮	S11

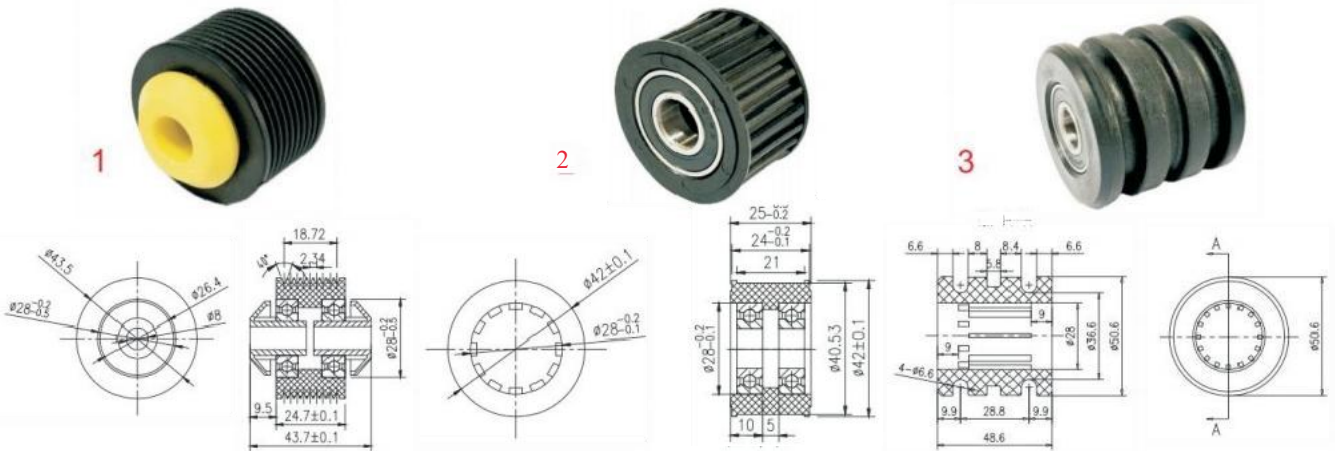

序号	品名	规格	用途
1	多楔带轮过渡轮组件	9沟8槽	伸缩机同步带线
2	同步带轮过渡轮	T5-26齿	
3	50-0带轮过渡轮	双槽	

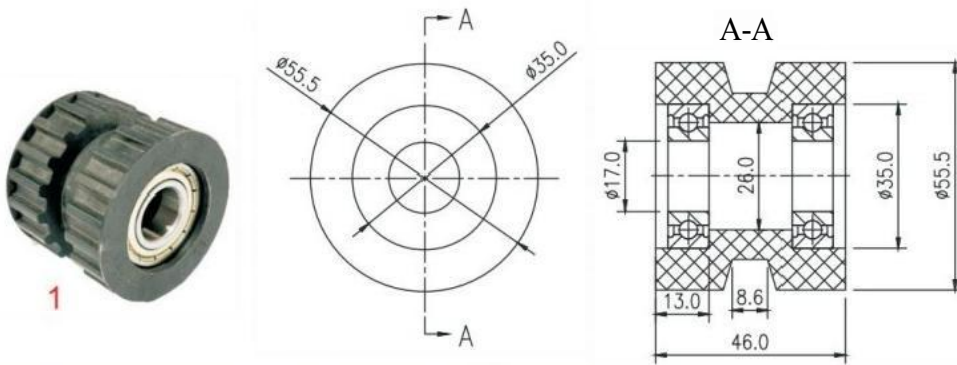

序号	品名	规格	用途
1	同步带轮	T10-18齿双排	移载机

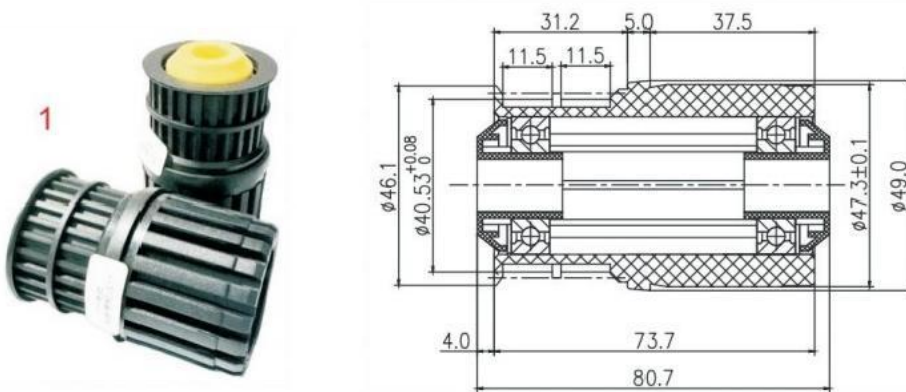

序号	品名	规格	轴径
1	一体式同步带轮	T5-26齿	12轴、S11六角轴、15轴

挡圈

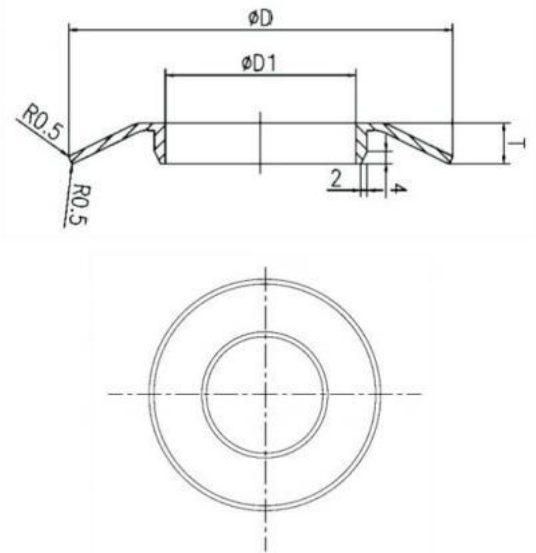

序号	型号	材质	D	D1	T
1	50挡圈	碳钢/不锈钢	80	50	10
2	60挡圈	碳钢/不锈钢	120	60	12
3	76挡圈	碳钢/不锈钢	135	76	11.5
4	89挡圈	碳钢/不锈钢	150	89	15.8
5	60活动挡圈	碳钢/不锈钢	120	60	13.4
6	76活动挡圈	碳钢/不锈钢	135	76	13
7	89活动挡圈	碳钢/不锈钢	150	89	17
8	76活动挡圈	铝合金	135	76	23.5
9	80活动挡圈	铝合金	135	80	23.5
10	89活动挡圈	铝合金	150	89	25

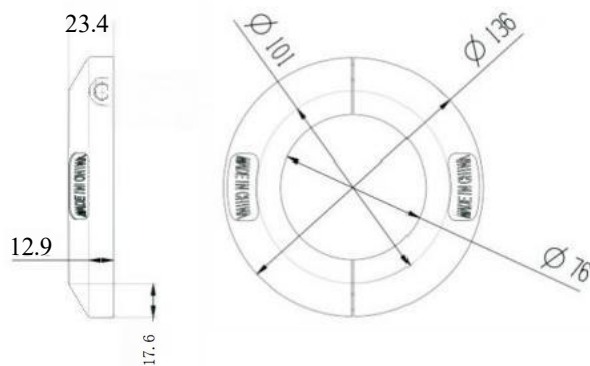

铝挡圈



轴壳

B



ΦD
001

ΦD
Φ

ΦD
801

e



序号	规格	ΦD	A(非标轴承)	B(小黑头)	轴径
1	321.2	Φ29.8	5.5mm		8轴
2	381.2	Φ35.8	5.5mm	5.5mm	12轴
3	381.5	Φ35.2	5.5mm	5.5mm	12轴
4	501.5	Φ47.2	5.5mm	5.5mm	12轴、15轴
5	502.0	Φ46.2	5.5mm		12轴、15轴
6	601.5	Φ57.2	5.5mm		12轴、15轴
7	602.0	Φ56.2	5.5mm	5.5mm	12轴、15轴、20轴
8	762.0	Φ72.2	5.5mm		15轴
9	762.5	Φ71.2	5.5mm	5.5mm	15轴、20轴
10	763.0	Φ70.2	5.5mm	5.5mm	20轴
11	893.0	Φ83.2	5.5mm		20轴
12	381.2(304不锈钢)	Φ35.8	5.5mm	5.5mm	12轴
13	381.5(304不锈钢)	Φ35.2	5.5mm	5.5mm	12轴
14	501.5(304不锈钢)	Φ47.2	5.5mm	5.5mm	12轴、15轴
15	601.5(304不锈钢)	Φ57.2	5.5mm		15轴
16	602.0(304不锈钢)	Φ56.2	5.5mm	5.5mm	15轴
17	501.5(积放)	Φ47.2			12轴
18	502.0(积放)	Φ46.2			12轴
19	601.5(积放)	Φ57.2			12轴、15轴
20	602.0(积放)	Φ56.2			12轴、15轴

PVC软胶套



序号	名称	规格
1	50软胶套	Φ 50*2mm
2	60软胶套	Φ 60*2mm

PVC管



序号	名称	外径	厚度
1	PVC管	60	3mm
2	PVC管	50	3mm
3	PVC管	50	2.5mm
4	PVC管	38	3mm
5	PVC管	38	2mm
6	PVC管	12	1.6mm

杯脚

8MM底板
焊死M20



8MM底板
活动M20



8MM底板
活动M16



6MM底板
活动M20



6MM底板
活动M16



5MM底板
活动M16



5MM 底板
活动M14



3MM 底板
活动M14



3MM底 板
活动M14



3MM底板
活动M12

不锈钢
杯脚



发黑杯脚

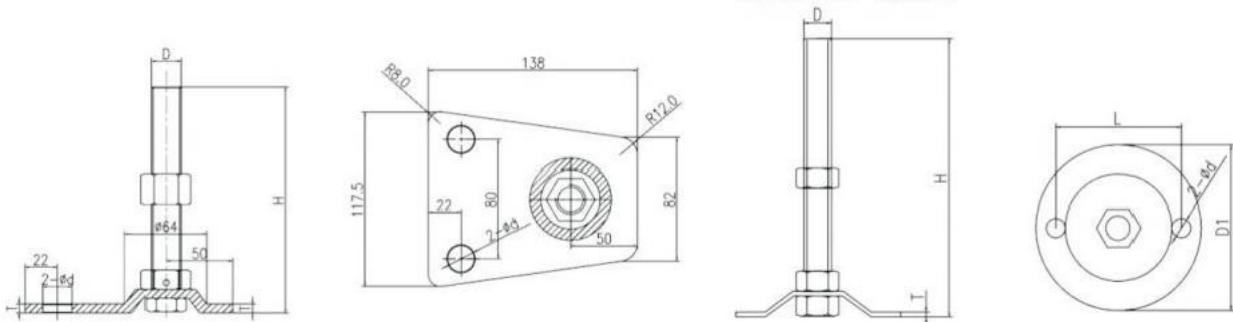

序号	型号	材质	H	T	D	d	D1
1	鸭掌杯脚8MM底板焊死M20	碳钢/不锈钢	150	8	20	19	/
2	鸭掌杯脚8MM底板活动M20	碳钢/不锈钢	150	8	20	19	/
3	鸭掌杯脚8MM底板活动M16	碳钢/不锈钢	150	8	16	19	/
4	鸭掌杯脚6MM底板活动M20	碳钢/不锈钢	150	6	20	16	/
5	鸭掌杯脚6MM底板活动M16	碳钢/不锈钢	150	6	16	16	/
6	圆形杯脚5MM底板活动M16	碳钢/不锈钢	150	5	16	12	120
7	圆形杯脚5MM底板活动M14	碳钢/不锈钢	150	5	14	12	120
8	圆形杯脚3MM底板活动M14	碳钢/不锈钢	140	3	14		95
9	圆形带勾杯脚3MM底板活动M14	碳钢/不锈钢	120	3	14	10	80
10	圆形杯脚3MM底板活动M12	碳钢/不锈钢	120	3	12	/	80

